



## **2012 ProStocks SPECIFICATIONS**

### **VIOLATIONS**

When referring to the engine, gearbox, differential, mechanical or construction, rules and regulations the principle will always be: Unless permission is specifically granted to make modifications, or any variation, nothing may be done to alter or change in any way the standard Parts.

Unless these rules state you can do it, you "CANNOT DO IT".

Cars, Engines and Fuel will be checked on a random basis.

Violations will result in an immediate suspension of all racing facilities and any refusal will also result in an immediate suspension .

All car and engine specifications will be taken from the Technical Service Data book for cars as published by Glass's Guide Service Limited. Technical queries can be addressed to, The Secretary, ORCi Limited, Technical Committee, P.O.Box 9889, Birmingham, B43 6WA.

Drivers are reminded that scrutineer checks can be carried out at any time, and most certainly at official championships. If parts are suspected of being illegal make sure you leave them with the promotion if you do not agree or if you refuse it will automatically make the part or parts illegal.

**It is the responsibility of the driver to prove to the promotion that the part is legal by the way of written proof of where the part originated. This must be done within seven days, otherwise the part(s) in question will be deemed to be illegal and will result in immediate suspension from racing and referral for disciplinary action.**

### **CAR CONSTRUCTION RULES AND REGULATIONS**

#### **INTRODUCTION**

This formula is designed to encourage new drivers to our circuits to enjoy the atmosphere and thrills of driving on an oval without substantial financial investment or for those drivers who cannot give the commitment necessary to compete at the very high level of all our present Formulae. Drivers who have achieved a grade of blue or higher in any other senior formula other than Bangers over the last 5 years cannot drop below **RED Grade** in Pro - stocks. Any dispensation on this rule must be approved by the GMP Board of Control.

Pro - STOCKS feature cheap cars in LIMITED CONTACT racing. The concept of the racing is to nudge or spin out the car in front rather than the intentional fencing of National Bangers. Cars seen to deliberately fence, steer other cars into parked cars, follow in or other acts of intentional wrecking will be suspended from the meeting and face a further period of suspension at the discretion of the Board of Control.

***Any of the following driving infringements will result in a suspension or a complete ban from ProStocks.***

- Spinning a car towards the fence or corner cutting to spin another car.***
- Deliberate following of another vehicle into the fence.***
- Driver retaliation (this will be looked at in the same light as the driver who committed the offence).***
- Dangerous driving***
- Attacking cars on the infield or chasing cars on to the infield.***

***NOTE: whilst any action not in the spirit of ProStock racing is carefully controlled by the Steward, in the case of a deliberate "follow-in", if proved, this could lead to an automatic lifetime ban from the formula. In the case of a track blockage, the excess hitting of stationery cars will be dealt with as any other driver infringement.***

**Champions will start at the back of the red grade. These will include National Points (Silver), World Cup (Gold), Scottish (Saltire), Points leader at last grading (Silver Stripe) will be the last Red roof.**

**If you win a race at a meeting; you will start the remaining races from the rear of your grade. Should you win another race at the same meeting – you will be automatically upgraded to the grade above and will remain in this grade for the remainder of the grading period.**

#### **WHAT YOU NEED TO GO RACING**

A crash helmet, which should be to the current ORC specification

A Pair of fireproof brightly coloured overalls.

A 4 or 5 strap, full safety harness as per regulation 6 .

A quick release cloth window net must be fitted to the driver's door window aperture. (see section 17 below).

A Fire extinguisher 1Kg (2lbs) dry powder with a level indicator dial.

A Good seat with head restraint.

Transponders must be fitted while racing at all tracks including Sheffield, Buxton, Spedeworth, Belle Vue, & Northern Ireland.

An application form to obtain a GMP drivers licence. (The form and payment must be received 7 days prior to a race meeting – forms and fixture lists are available from the GMP office).

#### **1. CARS ELIGIBLE**

**The following cars eligible for 2012:-**

**Ford, Escort1600 (see engine rule7 below), Focus, Sierra & Orion.**

**Vauxhall, Astra, Cavalier & Corsa “c”. (No Nova or Corsa other than “c”).**

**A run out period for all other existing Cars already raced will be until May 2012.**

**In Northern Ireland only, due to the later start to the season than in Scotland, existing cars may be run out until June 30<sup>th</sup> 2012. In the intervening period these cars will not be eligible for any championship races.**

Anyone wishing to try another type of car should contact the Promotion for permission before they start any perpetrations.

#### **2. PREPARATION & Paintwork**

Remove all exterior mouldings/headlamps/door handles, exterior mirrors, bumpers and dash.

Remove all glass, interior trim, head linings, door linings, floor coverings, passenger seats.

**Any car arriving at the stadium with glass either fitted or loose inside the car will not race. (NB it is not satisfactory to tape over bonded windscreen rubbers, they must be completely removed)**

All obsolete wiring must be removed. Tow bars must be **completely** removed together with spare wheel carriers.

A “quick release” nylon **window net must fitted** to the driver's door. **Steel mesh is not permitted.**

Grilles may be made from chicken wire if required, but must be fixed to car using screws & washers or pop rivets only – no extra metalwork is permitted.

**All cars must be neatly turned out at the start of each meeting.** Any driver arriving at a meeting with a car which, in the opinion of the scrutineer is in an unraceworthy condition will be refused racing.

The driver's racing number must appear on the doors of the car. They should be preferably in large American style numbers on a contrasting background. The bigger the better.

A 'Sun Visor' made of metal and having a depth of at least 6" may be fitted to the top of the windscreen aperture. The drivers name only must appear across the sun visor position. All sign writing must have a professional appearance.

Scrutineers will instruct drivers to change their numbers if lap scorers find it difficult to read them. The whole of the roof of the car must be painted in the drivers current grade colour. A ROOF FIN IS MANDATORY —BLACK ON WHITE. Each number on the Fin must be MINIMUM 9" HIGH x 1" WIDE. If your number cannot be read, you will NOT be lap scored.

Any car that does not comply with this rule will not be permitted to race.

#### **3. BODYWORK and BUMPERS**

No welding for strength. Front & back doors (**driver side only**) may be seam welded for safety but boots & hatches may only be tack welding. This is defined as a 2" weld with a 6" gap before the next weld.

All holes in the front bulkhead must be filled to provide a firewall between the engine and driver.

No panelling inside cars that is not easily removable for scrutineering. All areas must be able to be inspected.

All doors and bonnets must be secured shut.

A hole must be cut in the bonnet near to the carburettor, maximum size 6" .

DO NOT fill in head lamp or rear lamp apertures with anything other than 20 gauge aluminum with a maximum overlap of 2".

Front and rear bumpers **must** be removed and can be replaced with bumpers front and rear constructed from the following spec. 2" x 1" hollow section steel mounted by means of 2" x 5/16" flat bar. Bumpers can be welded or bolted to the original mountings or chassis. If flat bar is not used a 2"x1" box section bumper may be bolted (max 3 bolts) to the front or rear of the car.

The flat bar cannot be more than 6" inside the chassis leg. The bumper can be folded back at an angle to meet the front panel or front wing, where it can be bolted with a single 5/16" bolt and washer at each end. If the bumper is not bolted at either end, it must terminate 2" inside the front wing. A maximum gap of 1" is permitted between the bumper being fitted and the front / rear panel. You are not permitted to weld the box section bumper to the front panel. The rear bumper may be secured directly to the rear panel using 3 (1/2" max) bolts instead of being welded. Bonnets must have 6" or 10" corner plates welded or bolted to the scuttle panel / wing. Only two retaining bolts are permitted and can be a maximum of 1" dia. These are only permitted to pass through the slam panel or inner wing, or be bolted through, or welded to the chassis. Spacer / crush tubes are permitted up to 1 1/2 x 1 1/2 ". Washers of 4" x 4" x 1/4" are permitted. All bolts must be cut to 1/2" max above the washer. Shuttering bolts are permitted but the spinners/nuts must be taped for racing. A plate of a max 8" x 6" may be welded to the bonnet to take the bolts.

Boots and hatch backs may be bolted down however this is not compulsory, a maximum of 4 x 1/2" bolts will be all that is permitted to accomplish this. The maximum height of any bolt above the washer is 1 1/2". Boots are not permitted to be welded.

No double skinning of panels – 2" overlap maximum permitted.

No panelling inside of car i.e. doors, rear seat aperture etc.

Cars that are deemed to have excessive welding repairs will fail scrutineering. Wings must remain as standard & not be welded around the arch.

Bright colours for bodywork are recommended and a good overall appearance is mandatory. Cars may be sign written.

**Drivers may NOT paint their car in Team Colours or similar to that of other cars other than at organised team events.**

Mirrors may be fitted inside only.

**Scrutineers will fail cars that are not in a clean and tidy condition.**

#### **Door Plates**

A steel door plate must be fitted outside the drivers side front door to overlap the A & B posts by a minimum 2" and maximum 6". (see illustration) This must be a minimum 3/8" thick and 12" deep.

A maximum of eight bolts can be used to secure this plate, of which two must pass through the front pillar and two through the centre pillar or through an end plate that is welded to the roll bar. All bolts must be secured using washers made from flat bar to prevent bolts pulling through. All bolts must be trimmed to prevent injury.

#### **4. ROLL CAGE**

- You must fit as a **minimum** a single "hoop" roll bar in support of the door pillars, securely bolted to the roof and floor with a minimum size bolt of **3/8" (8mm)** and suitable washers.
- The hoop must be one piece or two uprights on one top bar of a welded construction.
- One cross bar is compulsory, a second is optional; these must be welded or bolted to the uprights and must support the drivers seat to stop it twisting.
- **THE ROLL BAR MUST NOT HAVE ANY REAR SUPPORTS but may have extensions no further forward than the B post (see diagram below). If used, these must be bolted through the B post.**

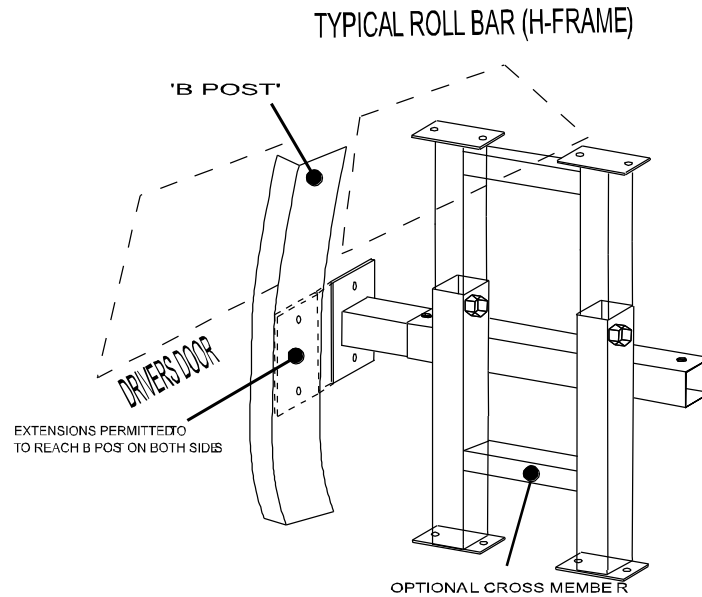

- The minimum size for roll bar is 1 1/2" (40mm), maximum size 4" (100mm), minimum thickness 3mm (75mm).
- Crossbars must have a 5" (125mm) square end plate fitted.
- The roll bar cross bars must be straight and no protrusion of cross bars must exist.
- Each upright must have a maximum of two bolts on each side to the floor and one each side at the top.
- No scaffold clamps allowed, all adjustable feet must be welded to the cage.
- The seat must be supported and secured at shoulder level to the cage, you may fit the 2<sup>nd</sup> cross bar in support of the seat just below the window aperture or weld a frame on the cage to support the seat at the top.

### **5. DRIVER'S SEAT**

A seat complete with a secure head restraint must be fitted. Competition seats may be used though no seat featuring a rib protector is permitted. The seat must be securely mounted at shoulder height to the cross bar or to the rollover bar and bolted securely to floor. When the driver is securely belted in the car, i.e. ready for racing, there must be a minimum gap of 4" between the top of the driver's crash helmet and the roof of the car.

### **6. SEAT BELTS**

Only belts comprising separate shoulder and lap straps will be permitted. All belts must connect to the quick release buckle. In the case of NASCAR lever latch buckles, it is advisable to fit a secondary means of detent to prevent overall sleeves accidentally unhooking buckles during racing. A small section of tubegrip elasticated bandage slid over the hooked buckle serves this purpose. Special attention must be paid to the condition of seat belts and fixings once fitted. An extra bar is to be fitted to the roll cage behind drivers seat, approximately 4" below shoulder height of driver. Seat belts may be fixed to this bar or allow the belts to lever over it. Information is available from your promotion on the correct procedure to follow when fitting seat belts, remember, your life depends on them..

### **7. ENGINES**

Maximum engine size 1600cc and must remain standard no competition parts are allowed (i.e. Valve springs, cam shafts, valves, pistons etc.). **Standard recondition procedures** max over bore +60.

The Ford 1600 16v engines must run with the cam shaft specified below.

Only the camshaft with 4 single shadow rings are allowed as in the picture below and rings must be in the same position as the image



Vauxhall cars can run pierburgh 2e or varijet carb from the vauxhall range main jet sizes can be enlarged all other internal parts to be standard cold start dev. Can be removed Chokes may be modified to open together

The Ford Escort 1600 16v engines may be used & can be fitted with the standard Weber 32/36 DGV or DGVA carburettor may be used with a maximum of 26mm and a 27mm sized chokes. No polishing or re-profiling is allowed. No modifications to the carburettors body or original design. **The interchanging of the carburettor top from other Weber models is not allowed.** All gaskets must remain standard and original. A single original spec insulator block must be fitted between carburettor and inlet manifold, with two gaskets; approximate total thickness = 5mm. Main jets, primary and secondary jets, auxiliary venturi and emulsion tubes may be changed but must face downwards towards the butterflies. Accelerator pump jets may be changed but face downwards towards butterflies. Chokes may be modified to open together and replacement spindles may be fitted with standard screws. Cold starting devices may be removed with retaining lugs and subsequent holes blanked off. Air and fuel galleries may not be enlarged or modified, and fuel may enter on either side. Floats may not be modified or weighted, and must control the fuel flow. Needle valves may not be larger than **150**, and not enlarged or modified. The power valve must be fitted in the base of the bowl, but may be sealed off, and the diaphragm may be removed. No trumpets are allowed. It is permitted to use a grub screw or similar device to fix the auxiliary venturi to the carburettor body. Top end enrichment devices may be blanked off or modified. A secondary fixing on the fuel inlet feed line is required. The Inlet manifold must be standard & not faced to alter the angle of the manifold to the carburettor. No inlet port matching of the carburettor to the manifold or the manifold to the head. No material may be added or removed from the gas flow area, it must be as standard.

A standard electric fuel pump that can be used in any car.

Air filter may be removed.

**Exhausts** must come from the range of car to which they are fitted and must not be altered in any way from original. They must terminate just in front of the rear axle 2" max no further forward. Repairs are permitted to the system. Cars fitted with cats can removed them and replace with straight pipe to the same diameter and length. Everything else must remain as manufactured.

Engine Identification marks must be clearly visible to scrutineers.

## **8. GEARBOX / AXLE**

Gearbox must be as manufactured to the same vehicle range.

Axle and ratio must be as manufactured.

Locked differentials are not permitted other than on shale tracks. Viscous diff's are not permitted.

## **9. RADIATORS**

Any radiator may be used but it must be fitted in original position. Brackets may be used to secure rad's but must originate from engine block or engine mountings and must not be considered offensive. No extra cooling is

permitted other than the radiator and header tank. Heater matrixes must be removed. Extra rubber hosing may be used to accommodate a different radiator to the standard fitment.

#### **10. BATTERY AND ELECTRICAL**

Must be securely fitted to, or as close as possible to, the roll bar and covered with a leak proof material. It must be isolated from fuel tank. Batteries must not sit forward of the driver (preferably they should be mounted on the rollbar).

All wiring must be fully insulated and an electrical cut-off switch must be fitted. Electrical starters must be fitted and be in working order. Ignition barrels must be situated well away from drivers knee.

#### **11. FUEL TANK**

The original fuel tank and lines must be removed. A maximum 2 gallon tank drawing fuel through a stand pipe outlet at the top of the tank must be used. It must have a secure screw-on metal cap and be fitted with a breather pipe fitted with a non return valve which will prevent spillage of fuel should the car be inverted. The tank must be fitted securely to the roll cage or in that area, clear of the battery.

#### **12. FUEL SHUT OFF**

A manual shut off tap must be fitted within easy reach of the driver. Fuel pipes must be metal or metal covered when in car and securely clipped to prevent leakage. A 12" section of flexible pipe is permitted to fix line to carb, pump and tank.

#### **13. BRAKES**

The spec of the car used must be no better than the 1600 model i.e. brakes etc. must be as standard on the 1600 model or below & not as on a 2L model if a 2L shell is used (example Ford Sierra 1600 came with rear drum brakes, the 2L came with disc – therefore disc brakes not permitted) Must remain as manufactured in the 1600cc range of the car used and must be working on all four wheels. The handbrake must be in working order.

#### **14. WHEELS / TYRES / SUSPENSION**

Any standard road wheel up to 6j may be used 14" & 15". You must run the same diameter wheel on both front and back axles i.e. 14" must be 14" all round. **All four wheels must be of the same diameter.**

Hub caps must be removed.

All balance weights must be removed.

For 2012 we are going for the following controlled tyres Pirelli p6000 185/60/14, 185/65/14 or 195/50/15 and Yokohama A Drive ***Yokohama A Drive 185/65/14.***

From the first meeting in 2012 all cars must use at least 2 pirelli p6000 tyres or 2 Yokohama. And from the 1/5/2012 all cars must use only Pirelli p6000 tyres or A drive Yokohama. ***Yokohama A Drive 185/65/14. Also any Kingpin remould may be used.***

***Drivers at white and yellow grade may use any tyre upto £40 including vat, until they are upgraded to Blue or Red Grade.***

Road / Competition types and specials which have been discontinued are not permitted for use. Gaters are permitted to protect the tyres.

Any tyre with buffed markings will not be accepted, **any tyre found to be contaminated with tyre softener of any description will render the DRIVER to an immediate suspension from racing for 12 months.**

**The driver must be able to show proof of purchase to the promotion if questioned about any tyre he uses.** If this cannot be done then the tyre will be deemed illegal until the tyre can be checked.

Note: The promotion reserves the right to review the regulation relating to wheels and tyres at any time.

**Suspension** must remain standard except where stated and coil springs are free, and maybe any type but must fit the strut without modification to the original strut in any way. Rear coils maybe cut and welded.

Negative camber on the passenger side (N/S) front wheel can have up to a max of **10deg** or **30** mm which may only be achieved by drilling or slotting at the top or bottom of the suspension unit the strut top may also be slotted but not altered in any other way.

Cross members may be drilled or locating holes elongated to achieve this. Lead is permitted on the NSF wheel and can be achieved by extending anti-roll bars or compression struts and by re-drilling location holes to give a maximum of a 2" lead from standard.

#### **15. DRIVERS – ONE CAR PER MEETING**

Each driver is only permitted one car per meeting and each car is only permitted one driver per meeting.

#### **16. Steering Wheel**

A quick release steering wheel is permitted but must not be removed to exit car during races.

### **17. SAFETY EQUIPMENT**

*• Helmets must be of a minimum standard as directed by British Oval Racing Safety Executive (B.O.R.S.E). Snell SA2005, SFI Foundation 31.1A, SFI Foundation 31.2A. The E2205 European standard helmet may be used in Fibreglass or Tri-Composite form only. It is important that the helmet fits the driver correctly. Shatterproof goggles/visors must be worn although tinted visors are not advisable. Your helmet must display the current ORCi (ORC10) sticker.*

- Neck braces are recommended.
- Fireproof balaclavas are **MANDATORY** and must be marked appropriately.
- Fire retardant gloves are **MANDATORY** and must be marked appropriately. Drivers must wear bright coloured racing overall type clothing of flame retardant Proban or a high specification material and this must be maintained in a clean and tidy condition in view of the public.

N.B. If wet weather clothing is used this must be worn IN ADDITION TO and NOT INSTEAD OF the regulation flame retardant overall type of clothing described above.

- A quick release cloth window net must be fitted to the driver's door window aperture. The netting should have holes not larger than 7.5cm or 3" wide. It should come down level with the steering wheel, and should be flexible and easily removable separate to the movement of the door.
- A 1Kg Dry Powder Gauge Fire Extinguisher is highly recommended and if fitted, this should be in a tube with a spring top and should be within easy reach of the driver. Old type BCF (green) type extinguishers are not allowed. All tow vehicles, must carry a minimum of a 2kg fire extinguisher dry powder or gas, which must be within easy reach of the driver and mechanics at all times, especially when refueling.
- A minimum of 3" (75mm) wide safety belts (1.75" (40mm) sub-strap) are mandatory. This must be a full five point buckle release harness (including NASCAR type) with sub-strap and must be fitted and bolted to the floor and/or the roll cage. Shoulder belts with a sternum protection latch are highly recommended. The sub-strap must be used at all times and all belts must connect to the quick release buckle. In the case of NASCAR lever latch buckles it is advisable to fit a secondary means of detent to prevent overall sleeves accidentally unhooking buckles during racing. A small section of Tubegrip elasticated bandage slid over the hooked buckle serves this purpose. Special attention must be paid to the condition of seat belts and fixings once fitted.

**Please note that all of the above rules are subject to change in respect of Health & Safety requirements.**

**All tow vehicles, must carry a minimum of a 2kg fire extinguisher dry powder or gas, which must be within easy reach of the driver and mechanics at all times, especially when refueling.**

**Miscellaneous Safety is of primary importance in all motor racing. Please ensure that your car is well prepared with extra attention given to seat belts, possible fuel leakage, jagged edges on metalwork, clothing, crash helmet and when in the pit area, behave responsibly as other drivers depend on you!**  
**It is your responsibility to ensure that your car is built to the specifications, not the scrutineers !**

#### **18. TRANSPONDERS**

Transponders are mandatory and should be working at all times. They should be fitted 1.8 metres back from the front most position of the car. A hole of at least 6" (150mm) square is required in the floor, with the transponder fitted vertically, just below the hole. In the event of a dispute with the transponder result, the Steward of the meeting will make the final decision. Any driver found to have fitted the transponder further forward than the required 1.8 metres will be excluded up from the meeting.